



GENX6 Installation Guide

Installation of your new VTS device should be performed by a 12V certified technician or mechanic familiar with automotive 12V systems.

Model: GENX6



For vehicles with an OBDII style port (1996 or newer model years), our OBD connector is required for installation. The harness plugs directly into the vehicles OBDII port and into our device. The device can then be installed under dash as close to the windshield as possible.



If you wish to maintain the full use of your OBDII port, our OBD splitter allows you to maintain an open OBD port and power our device.



For vehicles with a J-Bus style port we offer various types of plugs to suit your installation needs. The harness plugs directly into the vehicles J-Bus port and directly into our device. The device can then be installed under dash as close to the windshield as possible.



9 Pin Green Power Harness: CAB-110351



6 Pin Gray Power Harness: CAB-110340



9 Pin Gray Power Harness: CAB-110331



INSTALLATION TIPS:

- The device should be installed under the dashboard with a clear line of sight to the sky, and as close to the windshield as possible. Place device with barcode decal "*THIS SIDE TOWARDS SKY*" facing up. (Reference diagram A)
- DO NOT install the unit underneath metal as the signal will not penetrate and reach the satellite.
- During initial installation, the vehicle should ideally be outside to ensure the best GPS signal. The devices may not report a location to the satellite if it is inside a garage or other structure.
- Secure the device with Velcro, and/or zip ties to ensure it is solidly mounted to the vehicle.
- Before finalizing installation, contact our technical support department at 631-339-7172 to verify the device is properly reporting to ***Silent Passenger***.



Ideal installation location



Improper installation locations

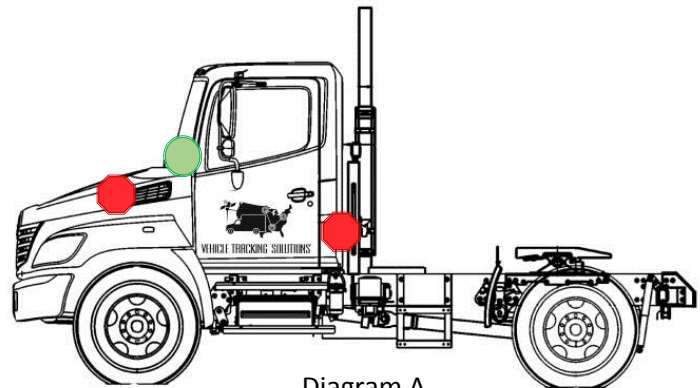
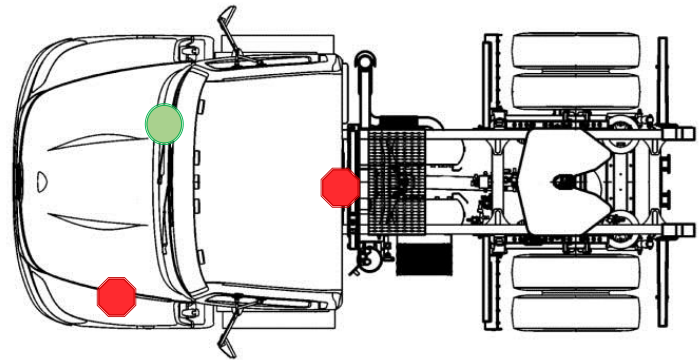

Diagram A

If you have any questions during installation, please contact our service department at 631-339-7171 for assistance. Before finalizing installation, please contact our technical support department at 631-339-7172 to have them verify the vehicle is visible in Silent Passenger and is registering properly.

IMPORTANT: Installation performed by anyone other than a 12V certified technician or mechanic familiar with automotive 12V systems may result in damage to your vehicle or injury.