



Driver ID Installation Reference Guide

Installation of your new VTS device (Diagram A) should be performed by a **12V certified technician or mechanic** familiar with automotive 12V systems.



Diagram A

Installation of Wiring Harness

- Connect the Red wire after the inline fuse to a constant 12V power source. (Diagram B, Ref. 1)
- Connect the White wire after the inline fuse to a 12V ignition source.
- Connect the Black wire to a solid ground source.

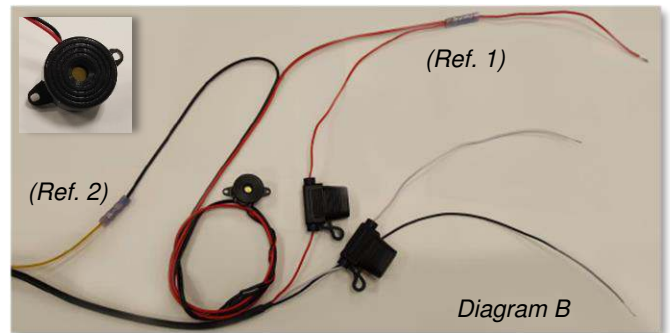

Installation of Driver ID Buzzer (Diagram B)

- Connect the **RED** wire to the 12V Source on the wiring harness. (See Diagram B, Ref. 1).
- The **Black** Wire will be connected to the **Yellow** Relay 2 output (-) wire at Pin 2 on the wiring harness. (Diagram B, Ref. 2)

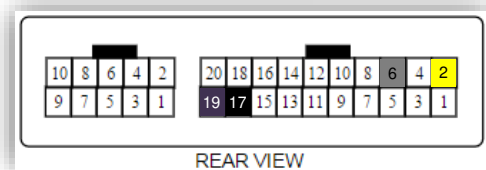

Installation of Driver ID Reader (Diagram C)

- Connect the **Gray** wire on the reader to the **Grey** wire coming from Pin 6 on the wiring harness. (See Diagram C, Ref. 1)
- Connect the 2 **Black** wires on the Reader to the **Black** ground wire coming from Pin 17. (See Diagram C, Ref. 2)
- Connect the **Blue** wire on the reader to the **Purple** wire coming from Pin 19 on the wiring harness. (See Diagram C, Ref. 3)

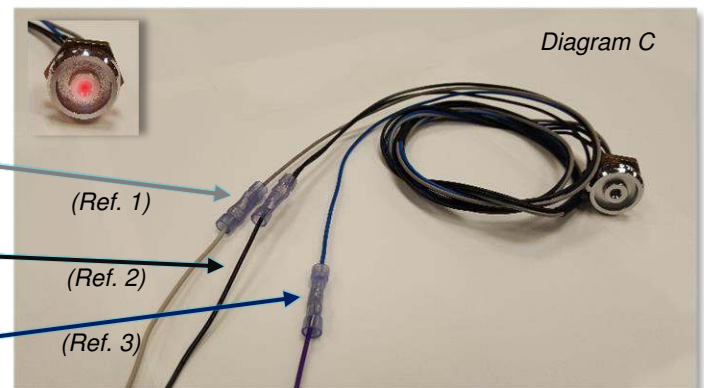



Installation Tips

- The tracking device should be installed under the dashboard with a clear line of sight to the sky, and as close to the windshield as possible. Place device with bar code decal facing towards the sky.
- DO NOT install the unit underneath metal as the signal will not penetrate and reach the satellite.
- During initial installation, the vehicle should ideally be outside to ensure the best GPS signal. The devices may not report a location to the satellite if it is inside a garage or other structure.
- Secure the device with Velcro, and/or zip ties to ensure it is solidly mounted to the vehicle.
- Before finalizing installation, contact our technical support department at 631-339-7172 to verify the device is properly reporting to **Silent Passenger**.



Ideal installation location



Improper installation locations

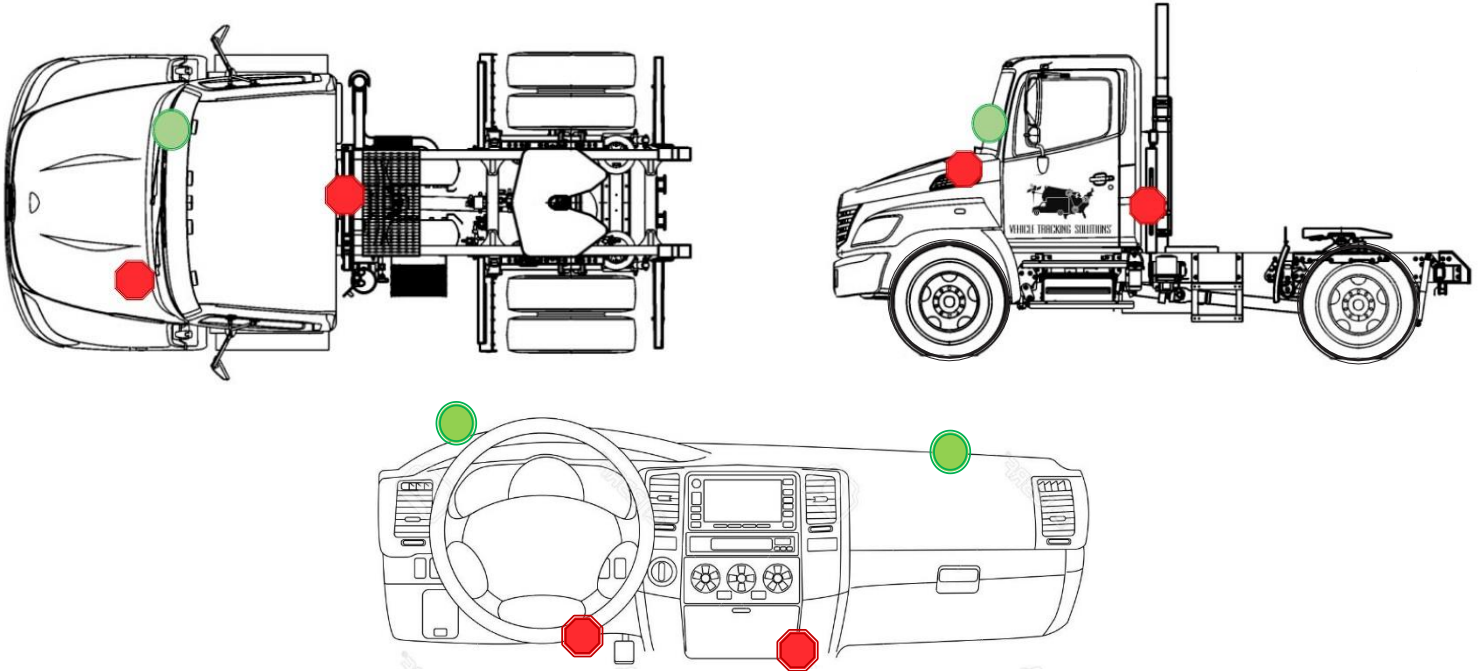

- If you have any questions during installation, please contact our service department at **631-339-7171** for assistance.
- Before finalizing installation, please contact our technical support department at **631-339-7172** to verify the vehicle is visible in Silent Passenger and is registering properly.
- **As with any automotive installation, there are risks of physical injury as well as potential for vehicle damage.**